



- Cast iron 3-jaw mandrel
- 2 steel shafts holding the mandrel, mounted on ball joint bearings on rollers set in the swivelling part of the base
- Connecting rod hydraulic expansion made of cast iron
- Fixed part of the base made of rolled steel
- Turret mounted on bearing pivot
- Motorised rotation of the turret to 180° through hydraulic motor and indexing through pneumatic cylinder
- Mandrel selection in the automatic mode via 2 electrical contacts
- Base made of rolled, welded steel
- Hydraulic generator and distributor integrated onto the turret

### RANGE AND FEATURES

Model	Max. load (kg)	Max. width without lateral guide (mm)	Max. width with lateral guides (mm)	Max. width with GLI2 (mm)	Expansion diameter (mm)	Max. outer diameter without wedge (mm)	Weight (kg)	Electrical power 400 V - 50 Hz	
								FPS - MO	VV
<b>D 2384 D</b>	2 x 6500	580	420	520	470 to 530	1500	3200	2.5	7.5
<b>D 2384 F</b>	2 x 6000	800	640	800	470 to 530	1500	3500	2.5	7.5
<b>D 2384 G</b>	2 x 5500	1000	840	1000	470 to 530	1500	3800	2.5	7.5
<b>D 2384 H</b>	2 x 5000	1300	1140	1300	470 to 530	1500	4100	2.5	7.5

### DIMENSIONS

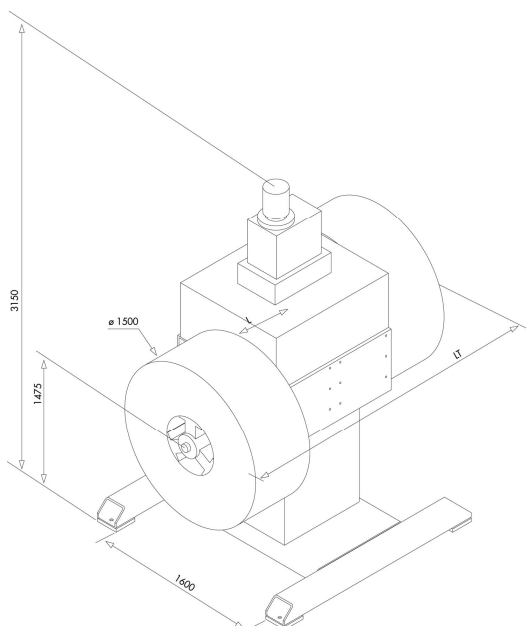

Model	L	LT
<b>D 2384 D</b>	420	2680
<b>D 2384 F</b>	640	3120
<b>D 2384 G</b>	840	3520
<b>D 2384 H</b>	1140	4120